



Low Clearance Split Frame

SPECIFICATIONS

- Cutting Tool Surface Speed:** 60 Surface Feet per Minute
- Drive Options:** Pneumatic, Hydraulic, or Electric
- Air Requirements:** 65 Cubic Feet per Minute @ 90 PSI or 1.7 Cubic Meters per Minute @ 6.2 Bar
- Hydraulic Requirements:** 8 Gallons per Minute @ 1,500 PSI or 31 Liters per Minute @ 104 BARS
- Feed Method:** Star Wheel
- Feed Rate:** Fixed @ .0026" per trip
- Finish:** Hard Chrome Plating
- Packaging:** Heavy duty carrying case

Standard Equipment:

- Self Squaring Mounting System
- Fitted Storage Case
- Operating Tools
- Operating Manuals

Optional Equipment:

- Bridge Slide for Single Point Beveling of Heavy Wall Pipe
- Low Clearance Tool Slides
- Extended Tool Slides
- Worm Gear Tool Slides
- Pneumatic, Hydraulic or Electric Drive Options
- Extension Legs for Pipe, Elbows and Fittings and Thin Wall Applications
- Tooling for all Prep Configurations

RADIAL AND AXIAL CLEARANCE CHART

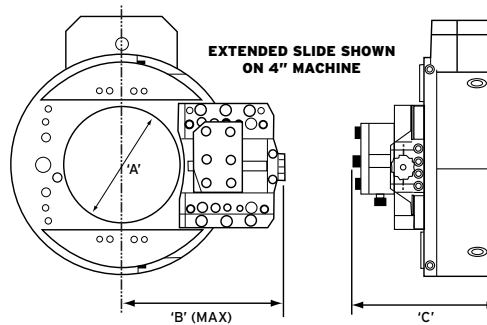

OPTIONAL INTERCHANGEABLE TOOL POSTS

Allows the operator to convert from low clearance tool slides to extended slides in minutes.



MODEL	SF 204/3	SF 206/3	SF 408/3	SF 610/3	SF 612/3	SF 814/3	SF 1016/3	SF 1420/3	SF 1824	SF 2228	SF 2632	SF 3036	SF 3642	SF 4248
A Dim. (in)	4.75	6.88	8.88	11.0	13.0	14.25	16.25	20.25	24.5	28.5	32.5	36.5	42.5	48.5
A Dim. (mm)	121.60	176.12	227.32	279.40	330.20	361.95	412.75	514.35	622.30	723.90	825.50	927.10	1079.5	1219.2
LOW CLEARANCE TOOL SLIDE (TOOL STROKE: .50") (12.7MM) USING SLIDE # 60-402-01/04														
B Dim. (in)	4.50	5.56	6.56	7.88	8.88	9.50	10.75	12.75	--	--	--	--	--	--
B Dim. (mm)	114.3	141.22	166.62	200.15	225.55	241.3	273.05	323.85	--	--	--	--	--	--
C Dim. (in)	6.0	6.0	6.0	6.0	6.0	6.0	6.0	6.0	--	--	--	--	--	--
C Dim. (mm)	152.40	152.40	152.40	152.40	152.40	152.40	152.40	152.40	--	--	--	--	--	--
EXTENDED TOOL SLIDE (TOOL STROKE: 1.50") (50.8 mm) USING SLIDE #60-415-00														
B Dim. (in)	6.45	7.51	8.51	9.94	10.94	11.45	12.70	14.70	16.63	18.63	20.63	22.63	--	--
B Dim. (mm)	163.83	190.75	216.15	252.47	277.87	290.83	322.58	373.38	422.40	473.20	524.00	574.80	--	--
C Dim. (in)	6.0	6.0	6.0	6.0	6.0	6.0	6.0	6.0	7.0	7.0	7.0	7.0	--	--
C Dim. (mm)	152.40	152.40	152.40	152.40	152.40	152.40	152.40	152.40	177.80	177.80	177.80	177.80	--	--
SUPER EXTENDED TOOL SLIDE (TOOL STROKE 2.00") (50.8mm) USING SLIDE # 60-437-00														
B Dim. (in)	--	--	--	--	--	--	--	--	19.0	21.0	23.0	25.0	28	31
B Dim. (mm)	--	--	--	--	--	--	--	--	482.60	533.40	584.20	635.00	711.2	787.4
C Dim. (in)	--	--	--	--	--	--	--	--	7.0	7.0	7.0	7.0	7	7
C Dim. (mm)	--	--	--	--	--	--	--	--	177.80	177.80	177.80	177.80	177.80	177.80
MACHINE CAPACITY (Nominal Pipe Size)														
in	1-4	2-6	4-8	6-10	6-12	8-14	10-16	14-20	18-24	22-28	26-32	30-36	36-42	42-48
mm	51-152	102-204	152-254	152-254	152-305	203-356	254-406	356-508	457-610	559-711	660-812	812-914	914.4-1066.8	1066.8-1219.2
WEIGHT														
(LBS)	30	37	43	53	63	73	88	103	175	200	230	260	310	360
(KGS)	13.6	16.78	19.5	24.04	28.57	33.11	39.91	46.72	79.38	90.72	104.32	117.93	140.6	163.29

E.H. WACHS COMPANY

100 Shepard Street • Wheeling, Illinois 60090 • 800.323.8185 • +1.847.537.8800 worldwide • +1.847.520.1147 fax

www.wachsco.com