



Gary Herman Companies, LLC.
4706 Curtis Lane
New Iberia, LA 70560
337-367-2880 www.alpha4rentals.com

HEAVY DUTY SERIES SPLIT FRAME

Cut Pipe and Face Flanges with one Machine

Wachs Heavy Duty Series Split Frame machines cut off, bevel, single point, counter bore and face flanges from 24" to 84" quickly and safely. All models are heavy duty and durable yet field portable and easy to use, making them ideal for pipeline and plant maintenance. Produce precision machined finishes in a fraction of the time it takes other cutting and prepping systems.



- Utilizes safe cold cutting process
Minimizes risk of explosion on gas and petrochem pipelines and will not alter the metallurgical quality of the pipe
- Set up, cut and prep 48" pipe, 5/8" wall in one hour
- Face flanges in heat exchangers without removing tube bundles for fossil fuel, petrochemical and nuclear applications
- Cut and bevel up to 3-inch wall pipe found in nuclear steam generators

Low Maintenance Rugged, Simple Design

- Steel construction, minimal frame parts
- Proven low friction adjustable bearing system spreads load evenly
- Tool slides and parts are interchangeable between machine sizes
- Heavy duty hinges and pin frame lock ensures machine rigidity

Fast Set-Up and Use

- Convenient lifting eyes provided for vertical and horizontal mounting
- Easy ratcheting mechanism opens and closes frame quickly
- Self squaring clamping system covers complete machine range
- Mounts to pipe with machine drive and tool slide installed – ready to operate
- Fast tool bit insertion and adjustment



HEAVY DUTY SERIES SPLIT FRAME

Interchangeable Tool Slides Utilize Standard Wachs Tools

- Parting Slide
- Beveling Slide
- Spring loaded slide for out of round pipe
- Counterbore slide
- Single point slide
single mount location for compound beveling and flange facing
- Bridge Slide
Dual mount for compound beveling and flange facing*

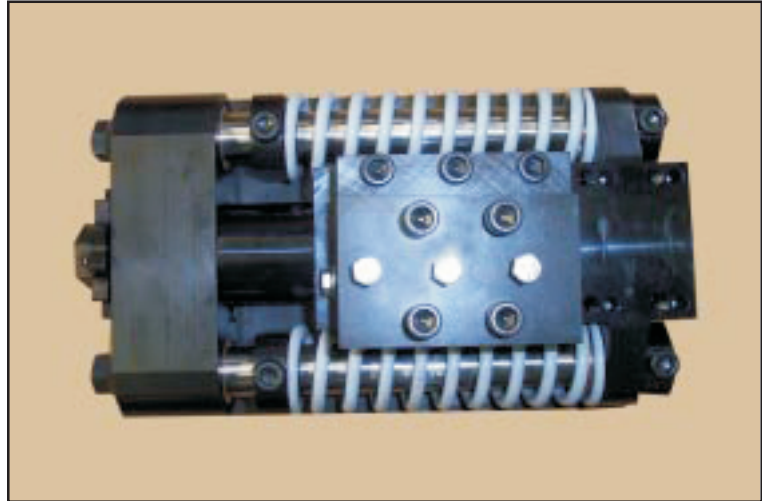

Spring Loaded out of round Tool Slide... cutoff and bevel

SPECIFICATIONS

Machine Drive:Hydraulic

Feed:Variable 0 to .030 per revolution

Feed Method:Star Feed

Hydraulic Requirements:10 gpm @ 1500 psi

Finish:Black Oxide and polyurthane paint

Range:

SF 2436	24" to 36" dia. pipe
SF 3648	36" to 48" dia. pipe
SF 4863	48" to 60" dia. pipe
SF 5684	56" to 84" dia. pipe

Weight:

SF 2436	950 lbs.
SF 3648	1,200 lbs.
SF 4863	1,450 lbs.
SF 5674	1,900 lbs

Bridge Slide:

Mechanical

Maximum tool travel: 12"

Feed rate: Variable 0 to .030 per relovution

Tooling: Insert and holder

Optional Availability

- Purchase or lease
- Short term rental
- Technical Training
- Full job responsibility with certified Wachs technician
**Application will determine tool slide selection.*

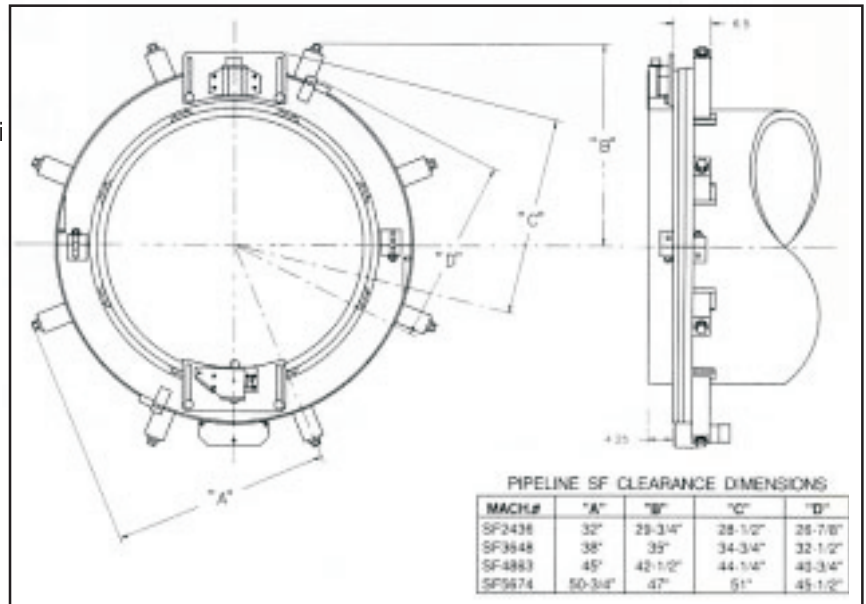

Standard Equipment

- Operating Tools
- Parting Slide
- Beveling Slide
- Hydraulic Drive Assembly
- Operating Instructions

Optional Equipment

- Spring loaded slide
- Counterbore slide
- Template slide
- Bridge slide



E.H. Wachs Company
600 Knightsbridge Pkwy. Lincolnshire, IL 60069
Phone: (847) 537-8800 • Fax: (847) 520-1147 • www.wachsco.com

Gary Herman Companies, LLC.
4706 Curtis Lane
New Iberia, LA 70560
337-367-2880 www.alpha4rentals.com