

# Goliath Guillotine Saws

## TOPSIDE AND SUB-SEA CUTTING APPLICATIONS

### 16" THRU 36" (406 – 914 MM) PIPE

#### [Saw Manual Standard](#)

#### [Saw Manual Auto Feed](#)

#### **FAST, SQUARE CUTS**

Wachs Goliath Guillotine has been designed to cold cut 16" to 32" (406 - 813mm) pipe of all materials, as well as solids, and multi-stranded casing strings. Along with its durable sub-sea design, Goliath provides easy set up and fast accurate cuts.

#### **VERTICAL OR HORIZONTAL MOUNTING**

The fabricated steel mounting saddle assures square cuts at right angles. The Goliath can be mounted in any position around the pipe. Integrated lifting attachments allow for horizontal as well as vertical positioning. The Goliath cuts equally well on vertical and horizontal piping. The heavy-duty clamping chain system secures it firmly to the pipe.

#### **HYDRAULIC DRIVE AND FEED SYSTEM**

The Goliath Guillotine features a twin hydraulic drive and mechanical feed system, which allows for manual and automatic feed control. The automatic feed design offers two feed settings. A 16" diameter 3/4" wall steel pipe is cut in only 24 minutes. A 32" diameter multi-stranded casing string is cut in about 48 minutes.

#### **BUILT FOR SERVICING THE OFFSHORE INDUSTRY**

The Goliath Guillotine incorporates corrosion treated steel components, chromed and ground steel guide rods, self lubricated bushings, bearings and seals and wipers. The addition of wipers and seals protect the moving parts from the abrasive effects of casing string grout. The self lubricating bearings and bushings allow the Goliath to operate sub-sea without worry of saltwater solvent washing away moving part or slide lubrication.

#### **SPECIFICATIONS:**

**Capacity:**

Cold cut all pipe material. 16"-32" (406 - 810mm) pipe

**Wall Thickness:**

Any wall thickness

**Clamping System:**

Chain clamping Feed Rate: 0.008 or 0.016

Hydraulic Ram

**Drive Motor:** 2 Heavy Duty Hydraulic Motors:

Standard 15 gpm @ 1500 psi (57 l/s @ 106 bar)

Autoclamp: 15 gpm @ 2000 psi (57 l/m @ 138 bar)

**Weight:**

Standard 1800 lbs. (818 kg)

Auto Clamp 2100 lbs. (955 kg)

**Autofeed rate:**

Low speed: 0.008" (0.020 cm) (per cycle)

High speed: 0.016" (0.041 cm)

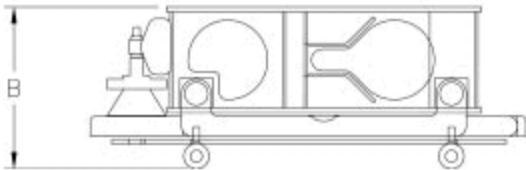
**Dimensions: Standard Clamp**

**A - 66" (168 cm)**

**B - 25" (63.5 cm)**

**C - 76-1/2" (194 cm)**

**D - 33" (83.8 cm)**

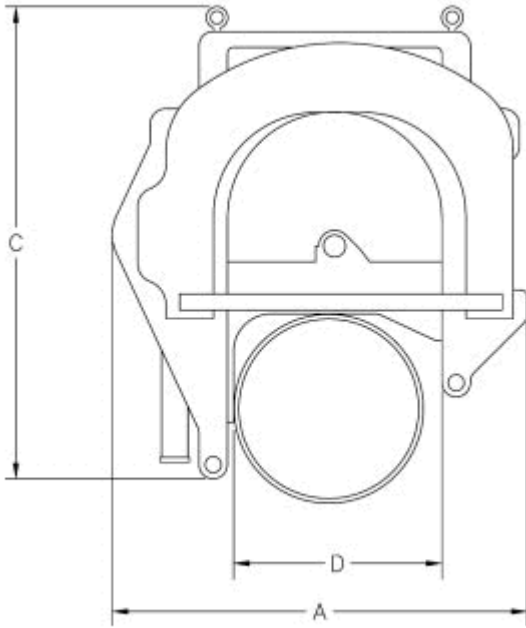

**Dimensions: Auto Clamp**

**A - 78" (198 cm)**

**B - 25.9" (65.9 cm)**

**C - 82-1/2" (210 cm)**

**D - 33" (83.8 cm)**

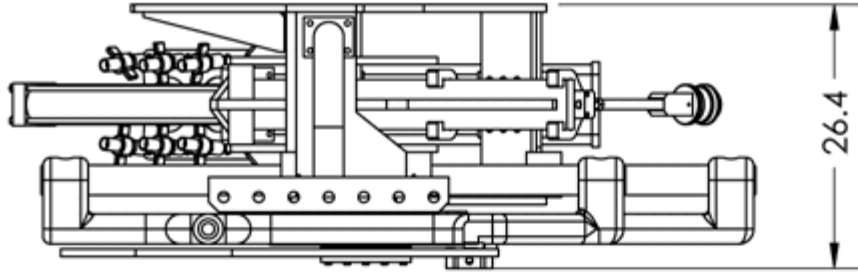
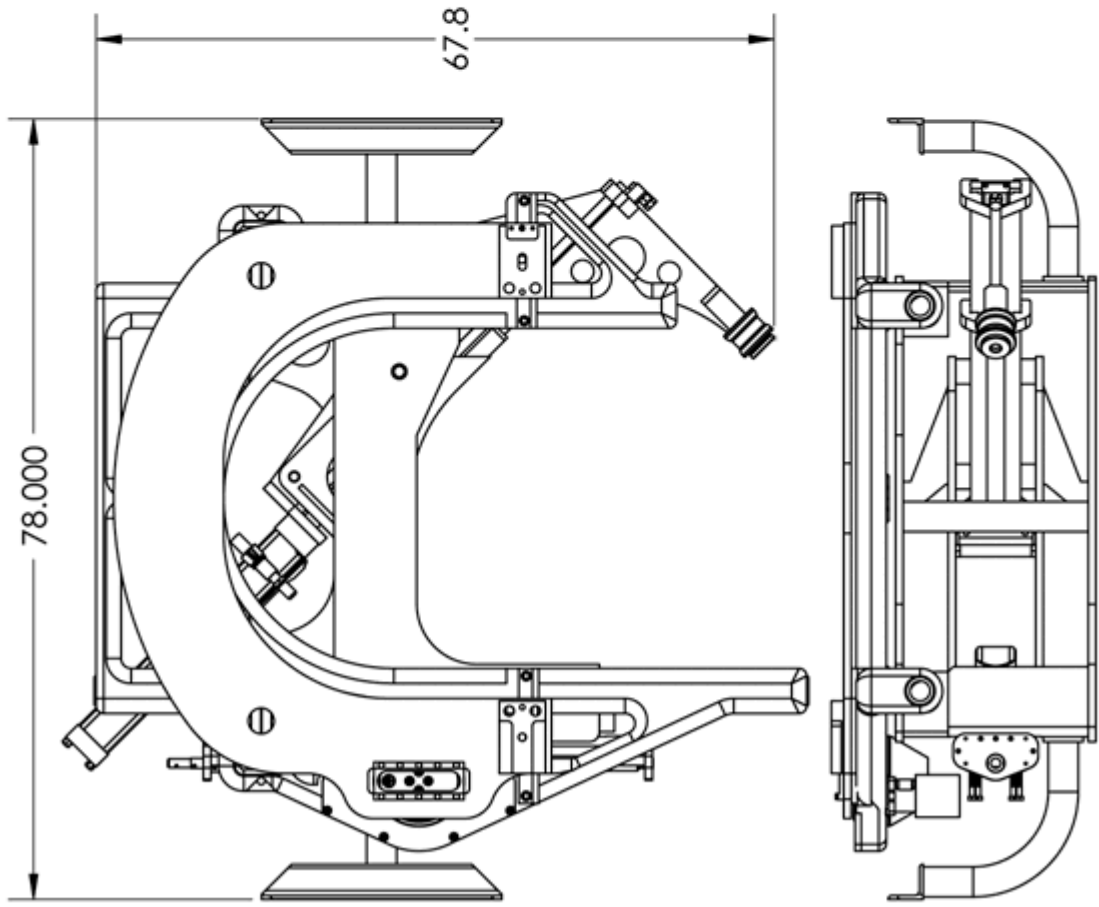

Weight: 2,100 lbs