

RWB

**Beckett**

INSTRUCTION MANUAL

**model SF**

OIL BURNER

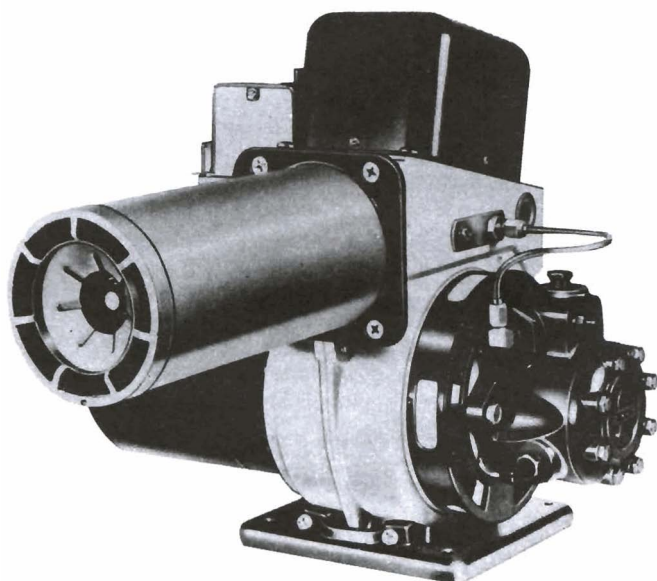
**SPECIFICATIONS****CAPACITIES MODEL SF**

..... 2.50 to 5.50 gallons per hour  
 ..... 350,000 to 770,000 BTU/HR Input  
 See SPECIAL AIR TUBE COMBINATIONS DETAILS For  
 Special Firing Rates

**FUELS**

No. 1 or No. 2 Heating Oil (ASTM D396) Only  
 In Canada, No. 1 or No. 2 Furnace Oil

**DIMENSIONS (Standard)**

Height ..... 13-5/8"  
 Width ..... 15-3/8"  
 Depth (Chassis Only) ..... 8-1/2"

**ELECTRICAL CHARACTERISTICS (See Note)**

Power Supply ..... 115 V/60 Hz 1 PH  
 Operating Load ..... (Max.) 7.1 Amps  
 Motor ..... 1/4 HP 3450 RPM, N.E.M.A. "N" Flange, manual  
 reset, overload protected

Ignition ..... 10,000 V/23 ma secondary, continuous  
 duty, shielded transformer or solid-state ignition system

**FUEL UNIT**

..... Suntec, or Webster

**NOTE:**

50 Hertz electrical components are available on special order.

Gary Herman Companies, LLC dba

**ALPHA RENTALS****337-367-2880****4706 Curtis Lane \* New Iberia, La**

Dear Homeowner:

Over forty years of engineering and product development have gone into your new oil burner. Its quality and design are unsurpassed. Properly installed and maintained it will provide many years of efficient, trouble-free operation. Please read this Instruction Manual carefully, and give special attention to the following points:

- An oil burner must have a generous supply of combustion air to operate properly. Please refer to the information in this manual for details.
- NEVER attempt to use gasoline in your heating appliance. Gasoline is more combustible than fuel oil and could result in a serious explosion. NEVER burn garbage or refuse in your heating appliance or try to light oil by tossing burning material into the heater
- **INSTALLATION AND ADJUSTMENT OF THE BURNER REQUIRES TECHNICAL KNOWLEDGE AND THE USE OF COMBUSTION TEST INSTRUMENTS. DO NOT TAMPER WITH THE UNIT OR CONTROLS. CALL YOUR SERVICEMAN.**

Beckett warrants its equipment specifically to those who have purchased it for resale, including your dealer. In the event of any problems with your equipment or its installation, you should contact your dealer for assistance.

**TO THE INSTALLER**

**INSTALLATION OF THE BURNER MUST BE DONE BY A QUALIFIED INSTALLER IN ACCORDANCE WITH REGULATIONS OF THE NATIONAL FIRE PROTECTION STANDARD FOR OIL-BURNING EQUIPMENT, NFPA NO. 31, AND IN COMPLETE ACCORDANCE WITH ALL LOCAL CODES AND AUTHORITIES HAVING JURISDICTION. FOR RECOMMENDED INSTALLATION PRACTICE IN CANADA, REFERENCE SHOULD BE MADE TO CSA STANDARD B139.**

**A QUALIFIED INSTALLER IS AN INDIVIDUAL OR AGENCY WHO IS RESPONSIBLE FOR THE INSTALLATION AND ADJUSTMENT OF THE EQUIPMENT AND WHO IS PROPERLY LICENSED AND EXPERIENCED TO INSTALL OIL-BURNING EQUIPMENT IN ACCORDANCE WITH ALL CODES AND ORDINANCES.**

**A properly designed chimney of adequate size and height and adequate combustion air supply are essentials for the best operation of any heating plant.**

**When installing the heater and/or burner be sure to provide adequate space for easy service and maintenance.**

**CONCEALED DAMAGE**

If any damage to the burner or controls is found during unpacking notify the carrier at once and file the appropriate claim.

Underwriter's Laboratories has certified this burner to comply with the commercial standards CS75, and has listed it for use with #1 or #2 fuel oil as specified in ASTM D396. State and local approvals are shown on burner rating label. The burner is certified in Canada by Canadian Standards Association (CSA). All oil burners should be installed in accordance with regulations of the National Fire Protection Association pamphlet #31 and in complete accordance with all local codes and authorities having jurisdiction. Regulation of these authorities take precedence over the general instructions provided in this installation manual. For recommended installation practice in Canada, reference should be made to CSA Standard B 139

**R.W. BECKETT CORPORATION**

P.O. Box 1289, Elyria, Ohio 44036,

**R.W. BECKETT CANADA, LTD**

430 Laird, Unit 3, Guelph, Ontario, N1G 3X7

## GENERAL INFORMATION

### FUEL UNITS & TUBING INSTALLATION

Burners are most commonly installed with a single stage fuel unit. This fuel unit, when connected with a supply line only, is satisfactory where the fuel supply is on a level with, or above the burner permitting gravity flow of oil. When it is necessary to lift oil to the burner, a return line should be connected between the fuel unit and tank. This requires insertion of the "by-pass" plug into the fuel unit. If lift exceeds approximately 10 ft., a two-stage pump should be installed with a return line.

When a return line is used, with either single or two-stage pumps, air is automatically returned to the tank making the unit self-purging.

Use of continuous runs of heavy wall copper tubing is recommended. Always use flare fittings. Avoid use of fittings in inaccessible locations. Avoid running tubing against heating unit and across ceiling or floor joists. If possible install under floor.

Specific information on piping, fuel unit connections, lift capabilities, and tank installations is provided in the instructions of the fuel unit manufacturer.

### COMBUSTION AIR

Burner must be installed in area with adequate fresh air available to support combustion.

Appliances located in confined spaces: The confined space shall be provided with two permanent openings, one near the top of the enclosure and one near the bottom. Each opening shall have a free area of not less than one square inch per 1,000 Btu per hour of the total input rating of all appliances in the enclosure, freely communicating with interior areas having in turn adequate infiltration from the outside.

### WIRING

The wiring must be in accordance with the National Electric Code and local codes and regulations.

Wiring diagrams are included in the heating unit installation instructions.

## UPGRADING OR CONVERSION

### ATTACHING AIR TUBE COMBINATION (CHASSIS PLAN ONLY)

If the air tube combination and oil burner chassis are packaged separately, the assembly is completed as follows:

1. Attach air tube to burner housing using four sheet metal screws. (If using an adjustable burner mounting flange, first attach flange to air tube.)
2. Insert nozzle line electrode assembly into tube and position nozzle from head, using 'Z' dimension shown elsewhere in these instructions. Check to be certain nozzle and head are concentric.
3. Secure escutcheon plate by tightening screw at side of housing.
4. Secure nozzle line using bulkhead lock nut. When a knurled lock nut is supplied, the recessed side is to face away from burner housing.
5. Attach connector tube (from pump to nozzle line). With long air tube combinations, insertion of the nozzle line electrode assembly into the air tube is facilitated by rotating the assembly 180° from its installed position, inserting it partially into the air tube, and then rotating it back to its proper position.

### SETTING THE BURNER

Use a mounting flange or pedestal as required.

The end of the burner air tube should be ¼" back from the inside surface of the front wall of the combustion chamber.

Insulate around air tube to prevent overheating of tube, nozzle and components. Make sure that insulation and cement do not obstruct face of burner head.

## IMPORTANT CAUTIONS READ BEFORE STARTING

### CAUTION: STAINLESS STEEL COMBUSTION CHAMBERS

The higher temperature levels produced by high-performance flame retention burners may exceed the temperature ratings of stainless steel combustion chambers and can result in chamber burn-outs.

Where a burner upgrading is being made in a unit with a stainless steel chamber, please observe **at least one** of these precautions:

1. Line the Chamber with a "wet-pac" ceramic liner.
2. Adjust inlet air to the burner so that the CO<sub>2</sub> level is below 11%.

### OIL

Before starting the burner be sure fuel tank is adequately filled with clean No. 1 or No. 2 furnace oil. *Crankcase oil, waste oil or GASOLINE should never be used.* Water, rust, or other contamination in the fuel supply system will cause malfunction and premature failure of the internal parts of the fuel unit.

### POWER CIRCUIT

Be sure that burner and controls are wired correctly and that the line switch is properly fused (20 amp). In Canada wiring to be done in accordance with the Canadian Electrical Code, Part I.

### NOZZLE

Be sure that specified nozzle is installed and that any covering over nozzle is removed prior to starting the burner.

### NOZZLE AND ELECTRODE SETTING

Be sure nozzle and electrodes are positioned as shown elsewhere in these instructions. Improper adjustment can result in oil impingement or ignition difficulties.

### AIR TUBE INSERTION

The burner head should be ¼" back from the inside wall of the combustion chamber. Under no circumstances should the burner head extend into the combustion chamber.

### FUEL UNIT

Be sure that fuel unit is arranged for the type of oil supply system installed . . . "One Pipe" or "Two Pipe". Be sure that all connections are tight.

Fuel units generally require manual venting of air when initially started. Failure to vent the air from the fuel unit through the vent plug provided may result in an air lock within the pump that will prevent oil from being delivered to the nozzle. See also Fuel Unit Manufacturer's instructions.

### LINE OIL FILTER

Use an oil filter of generous capacity for all installations. Install inside the building between the tank shutoff valve and the burner. For ease of servicing, locate the filter and a shut-off valve close to the oil burner.

### OIL SHUTOFF VALVE

Install approved high quality shutoff valves in oil supply line in accessible locations, one close to the tank and another close to oil burner, but ahead of the filter. Note that some types of filters are made with a built-in shutoff valve.

## STARTING AND ADJUSTMENT PROCEDURE

*Caution: Do not attempt to start the burner when excess oil has accumulated, when the furnace or boiler is full of vapour, or when the combustion chamber is very hot.*

1. Set thermostat substantially above room temperature.
2. Open shut-off valves in the oil supply line to the burner.

## HOMEOWNER INFORMATION

### OIL SUPPLY

Do not allow the fuel tank to run out of oil. During the summer be sure that your fuel tank is kept full; this will prevent condensation of moisture on the inside surfaces of the tank.

**IF YOUR TANK RUNS DRY, IT MAY BE NECESSARY TO MANUALLY VENT THE AIR FROM THE PUMP AND LINES WHEN RE-STARTING THE BURNER.**

### COMBUSTION AIR SUPPLY

Your burner requires a generous amount of clean combustion air in order to burn the fuel completely. Lack of adequate combustion air may result in erratic operation of the burner or noisy combustion or fuel odors in the air. Remember your need for outside air will be greatly increased if you have a vented dryer in the basement or other venting fans in the home.

### OILING MOTOR

Motor life will be increased by proper oiling. Use a few drops of non-detergent oil at both motor oil holes twice each year.

### FILTER

The line filter cartridge should be replaced every year to avoid contamination of the fuel unit and atomizing nozzle.

### AREA AROUND HEATING UNIT

Should be kept clean and free of any combustible materials - especially papers and oily rags.

### NEVER

Burn garbage or refuse in your heating unit. Never try to ignite oil by tossing burning papers or other material into your heater.

## SERVICE INFORMATION

"Preventive maintenance" is the best way to avoid unnecessary expense and inconvenience. Have your heating system and burner inspected at regular intervals by a qualified service man. If difficulty occurs, follow these simple checks before calling the service man.

1. Be sure there is oil in the tank and valve is open.
2. Be sure the thermostat is set above Room Temperature.
3. Be sure main Line Switch is "ON" and fuses are not blown.
4. Reset Safety Switch of Burner Primary Control.
5. Press Thermal Protector Button of Burner Motor.
6. If installation is equipped with Manual Reset Limit Control . . . Press Reset Button.
7. If burner runs but there is no flame, fuel unit may be air-bound. Follow instructions for venting fuel unit.

### THE FOLLOWING INFORMATION IS IMPORTANT IN SERVICING THE BURNER

1. Burner Components: If replacement of burner parts is necessary, always use parts recommended by the manufacturer. Specify part number & description when ordering.
2. Nozzles: Use of the correct atomizing nozzle is very important. If replacement is necessary, use the same type supplied by the manufacturer. Nozzle capacity and type are stamped on the hex-portion of the nozzle body. Use extreme care in handling nozzles to avoid scratches or dirt that could cause leaks or affect the oil spray pattern.
3. Electrode Setting is important for reliable ignition of the oil. Check to be sure setting is in accordance with instructions provided elsewhere in this manual.
4. Fan and blower housing should be kept clean of dirt and lint. If heating unit is located near unvented dryer, special care must be taken that lint does not restrict air passage in burner.

3. Check initial air adjustment. Normally the bulk air band (3) should be closed and the shutter (2) partially open:
4. Close line switch to start burner. If burner does not start immediately, re-set manual overload switches on motor and control.
5. Vent fuel unit as soon as burner motor starts rotating. To vent, loosen vent plug while holding an empty container under the vent opening to catch oil which will be expelled. Drain at least 1/2 pint of oil from the pump then close the vent plug. The ignition should be instantaneous with closing the vent plug.

If the burner starts and runs but stops again during the venting operation, wait three to five minutes for the safety switch to cool then re-set the manual switch and repeat the procedure until ignition is obtained. Sometimes after venting is accomplished and oil is ignited, the fire will again go out. This probably means that additional venting is necessary. Repeat the above venting procedure.

### AIR ADJUSTMENT

Adjust air supply by loosening lock screws and moving air shutter (2) and if necessary the bulk air band (3). Allow just sufficient air to obtain clean combustion determined by visual inspection. Reduce air supply until flame tips appear slightly smoky, then increase air just enough to make the flame tips appear absolutely clean.

### DRAFT CONTROL ADJUSTMENT

When the burner air supply and draft are properly adjusted the combustion chamber draft will normally be .01" - .02" WC. Larger installations may require slightly greater draft.

### FINAL ADJUSTMENTS

At this point a final adjustment should be made using suitable instruments for smoke spot and CO<sub>2</sub> (or O<sub>2</sub>) measurements. Unless otherwise specified in appliance manufacturer's instructions, the unit should be set as follows: After allowing 10 minutes for warm up, air should be set so that the smoke number is zero or a trace; less than no. 1 smoke is highly desirable and should never exceed this limit. (Note: Occasionally a new heating appliance will require longer warm up time in order to burn clean because of the evaporation of oil deposits on the heat exchanger and other surfaces. CO<sub>2</sub> measured in the stack (ahead of the draft control) should be a minimum of 10% for knocked down appliances or retrofit applications and a minimum of 12% for units with burners tested and supplied by manufacturers as a package.

Tighten all locking screws after final adjustments are made.

The unit should be started and stopped several times to make sure there are no significant rumbles or pulsations.

### CHECKING THE CONTROLS

Check and adjust all controls in accordance with the Control Manufacturer's instruction sheets. Be sure the primary control safety switch operates properly so that safety shutdown will occur in the event of equipment malfunction.

### FINAL CHECKS

Be sure air shutter and draft control are locked . . . that there is an ample supply of fresh air to the room in which the unit is located, and there are no oil leaks.

### INSTRUCTING THE HOMEOWNER

The operation and care of the heating system should be explained to the home owner, including how to adjust the thermostat, necessity of air supply to the burner, care of the burner, and the simple checks to make before calling for service if the burner fails to operate automatically.

# AIR TUBE COMBINATION DETAILS

## DIMENSIONAL RELATIONSHIPS

- "A" = Useable Air Tube Length
- "L" = "A" + 5/8"
- "R" = "A" + 2-7/8"
- "S" = 2-5/16"
- "Q" = "A" + 3 - 1/4"
- "Z" = 1-1/8"

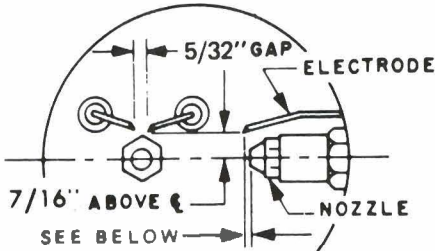

## ELECTRODE ADJUSTMENTS

NOTE - ELECTRODE POSITION AHEAD OF NOZZLE.

MODELS DIMENSION

F12, F22, F220, F310

1/16"

This dimension applies on heads with added flame ring only

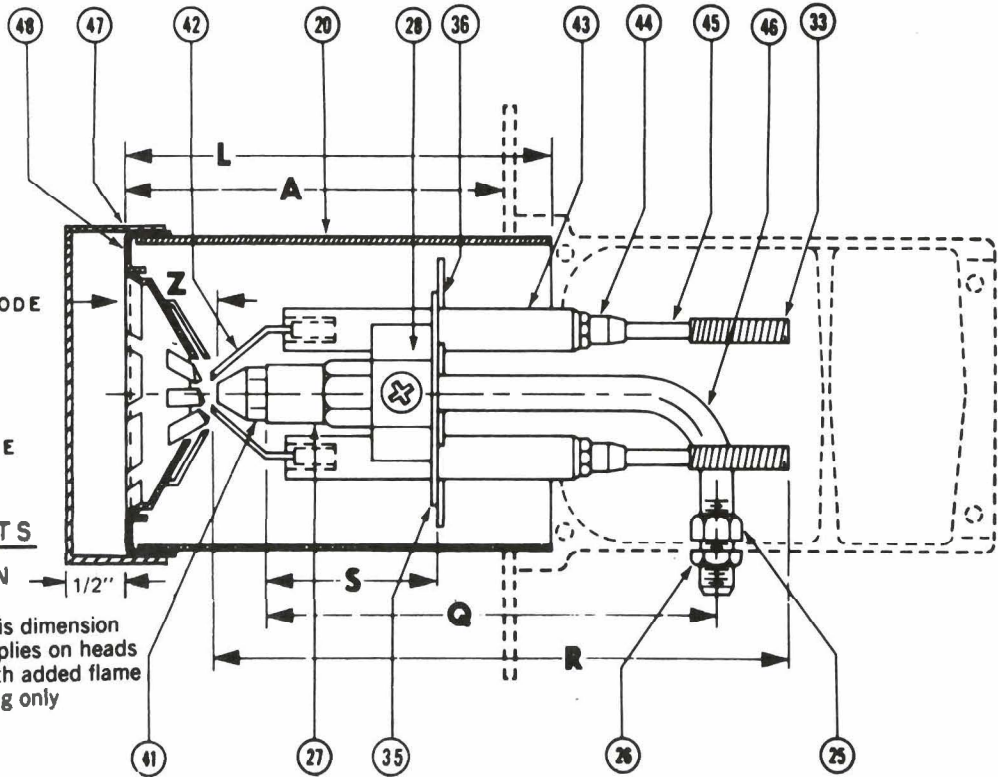

## AIR TUBE COMBINATION PARTS

20	Air Tube	Note
25	Nozzle Line Fitting (Pump End)	3-421
26	Lock Nut, Nozzle Line Fitting	3-666
27	Nozzle Adapter - Single	2-13
28	Electrode Clamp	1-49S
33	Contact Springs (as reqd.)	3-241
	Static Plate and Nozzle Line Support Assembly	Note
35	Centering Spider	5-653
36	Static Plate (See A.T. Combs)	3-383
	Static Plate Holding Screws	4-341
41	Nozzle	
42	Electrode Rod and Tip	Note
43	Porcelain	Note
44	Electrode Rod Extension Adapter, as reqd.	
45	Electrode Rod Extension, as reqd.	Note
46	Nozzle Line and Vent Plug	Note
47	Burner Head, (one piece head and shield)	
	Type F220 F310	

Note: Specify Burner model number "SF", part description; air tube combination with air tube length (Dimension "A") and firing rate.

## NOZZLES

UNIT APPLICATIONS: When burner is supplied as an integral component of a heater the best nozzle choice will have been determined by extensive testing. The heater manufacturers recommendation should be closely followed.  
 UPGRADING OR CONVERSION: Use 80° Solid Cone Nozzle.

## AIR TUBE COMBINATIONS

Air Tube Dimen. "A"	Firing Range G.P.H.			
	1.25-2.25	1.75-2.75	1.75-3.25	2.5-5.5
6-5/8"	SF65F0	SF65FP	SF65FD	SF65FT
9"	SF90F0	SF90FP	SF90FD	SF90FT
13"	SF130F0	SF130FP	SF130FD	SF130FT
16"	SF160F0	SF160FP	SF160FD	SF160FT
Head	F12	F22	F220	F310
Static Plate	2-3/4	2-3/4	None	None

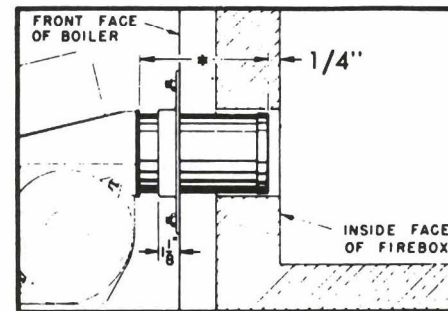

To determine

The Air Tube Length (") is the distance from the front of the burner housing to the face of the burner head and/or shield. (NOTE: Adjustable flange width - 1-1/8").

Gary Herman Companies, LLC dba

# ALPHA RENTALS

337-367-2880

4706 Curtis Lane \* New Iberia, La

**PARTS**

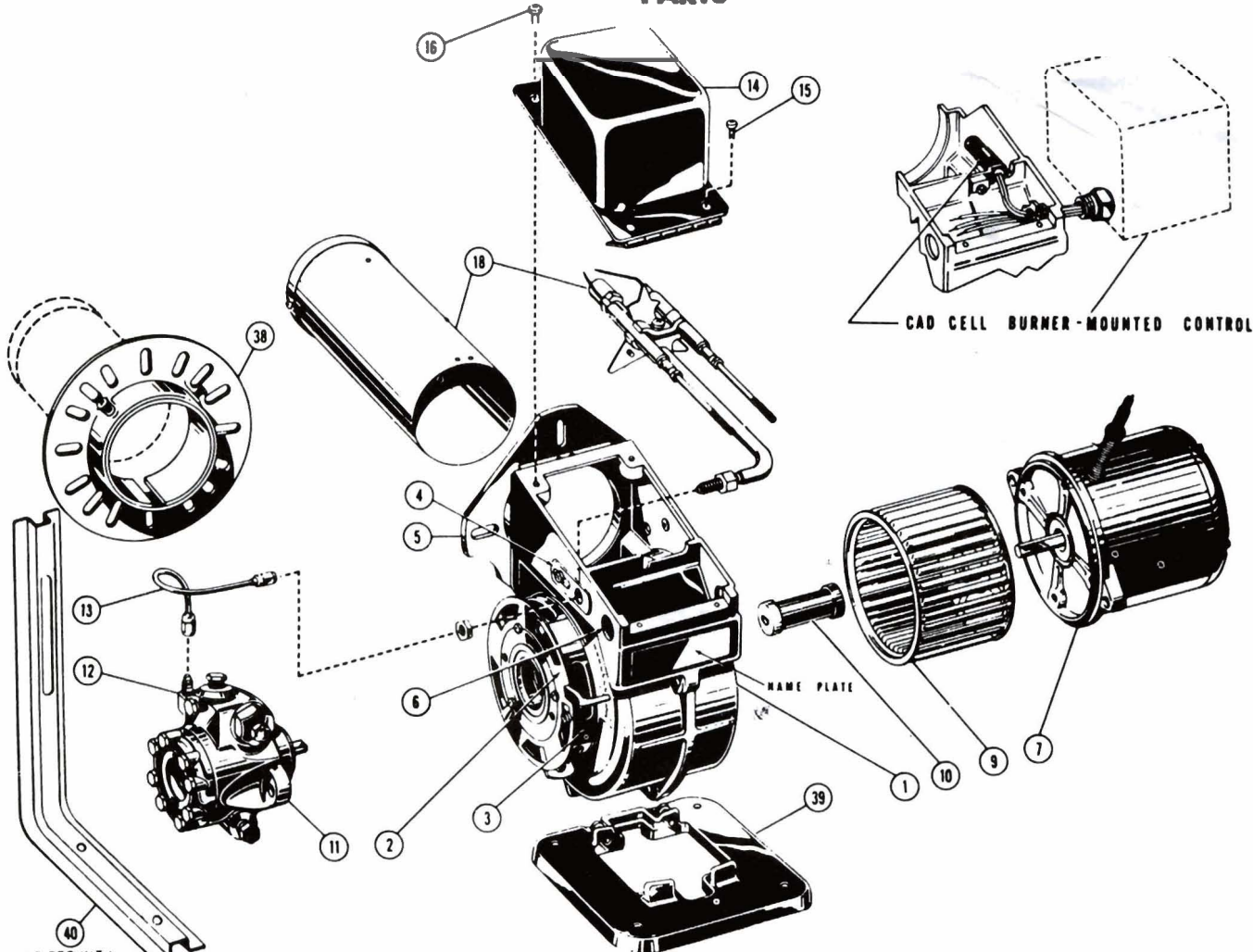

**WHEN ORDERING PARTS - STATE BURNER MODEL, PART DESCRIPTION AND PART NUMBER**

REF.	DESCRIPTION	PART NO.
1	<b>BURNER HOUSING ASSEMBLY</b>	
	Burner Housing with Inlet Bell . . . . .	5-348S
2	End Air Shutter . . . . .	3-215
3	Bulk Air Band . . . . .	3-819
4	Nozzle Line Escutcheon Plate - Front . . .	3-493
4	Nozzle Line Escutcheon Plate - Rear . . .	3-818
5	Unit Flange or . . . . .	3-230
	Square Plate . . . . .	3-399
	Holding Screws (not shown) . . . . .	
6	Hole Plug-Wiring Box (not shown) . . . .	2-139
7	<b>DRIVE MOTOR</b> . . . . .	2-364
	Motor Holding Screws . . . . .	4-82
9	<b>BLOWER WHEEL</b> Regular . . . . .	2-288
	Large (See Special Note) . . . . .	2-383
10	<b>FLEXIBLE COUPLING</b> . . . . .	†2-290
11	<b>FUEL UNIT</b>	
	Single-Stage Sundstrand "J" . . . . .	2-396
	Two-Stage Sundstrand "H" . . . . .	2-393
	Single-Stage Sundstrand "A" . . . . .	2-591
12	Pump Outlet Fitting . . . . .	2-256
	Pump Holding Screws (not shown) . . . .	4-82
13	Connector tube assembly pump to nozzle line . . . . .	5-394
14	Ignition Transformer (10,000V/23 ma.) . .	2-289
15	Hinge Screws . . . . .	4-217
16	Holding Screws . . . . .	4-292
17	Contact Spring Terminals(not shown) . .	3-245

REF	DESCRIPTION	PART #
18	Air Tube Combination . . . . .	*
	Air Tube Gasket (not shown) . . . . .	3-416
38	Adjustable Mounting Flange . . . . .	5-432
39	Pedestal Support . . . . .	5-685
40	Extended Pedestal Kit . . . . .	5-606
	*Specify Air Tube Combination (see overleaf)	

**SPECIAL NOTE:** When positive firebox pressure exists, large burner fan may be required. (See parts list)

**SUGGESTED COMBUSTION CHAMBER DIMENSIONS - UPGRADING OR CONVERSION**

Firing Rate (GPH)	Chamber Dimensions (in inches)				
	Round I.D.	Rectangular		Height	Floor To Nozzle
		W	L		
1.25	11	10	11	12	5-6
1.50	12	11	12	13	6-7
2.00	14	12	15	13	6-7
2.50	16	13	17	14	7-8
3.00	18	14	18	15	7-8
3.50	19	15	19	15	7-8
4.00	20	16	21	16	8-9
5.00	23	18	23	18	9-10
5.50	24	19	24	19	10-11

†Use Coupling No. 2-433 With Model A Fuel Units

